

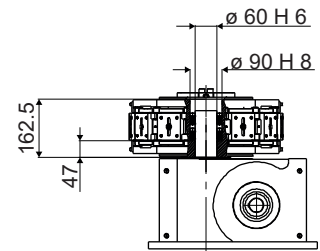

# TXL 100

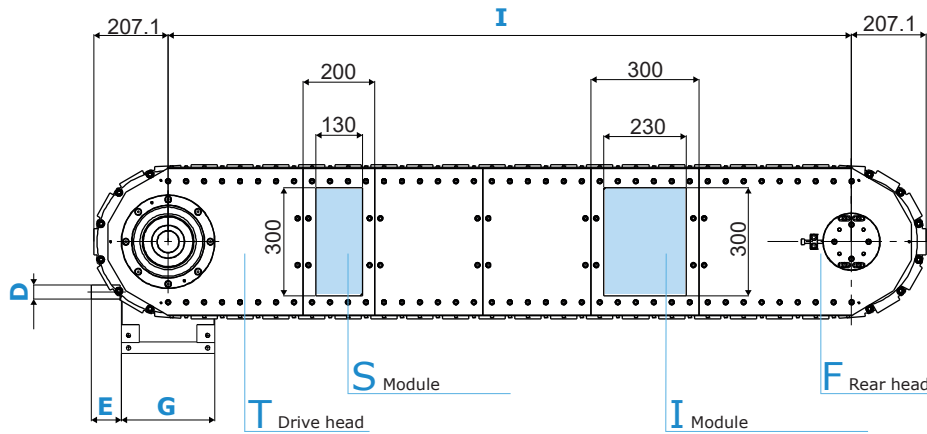

Area available on each element for tooling or through opening • Area disponibile in ogni modulo per lavorazioni o per apertura passante • Verfügbar sind Werkzeuge oder Öffnungen auf den einzelnen Flächen der Elementen  
 • Surface disponible sur chaque module pour montages appuis de fixation ou passage • Area disponibile in cada módulo para elaboración o apertura pasante • 每个链节上都有工作和通过的区域

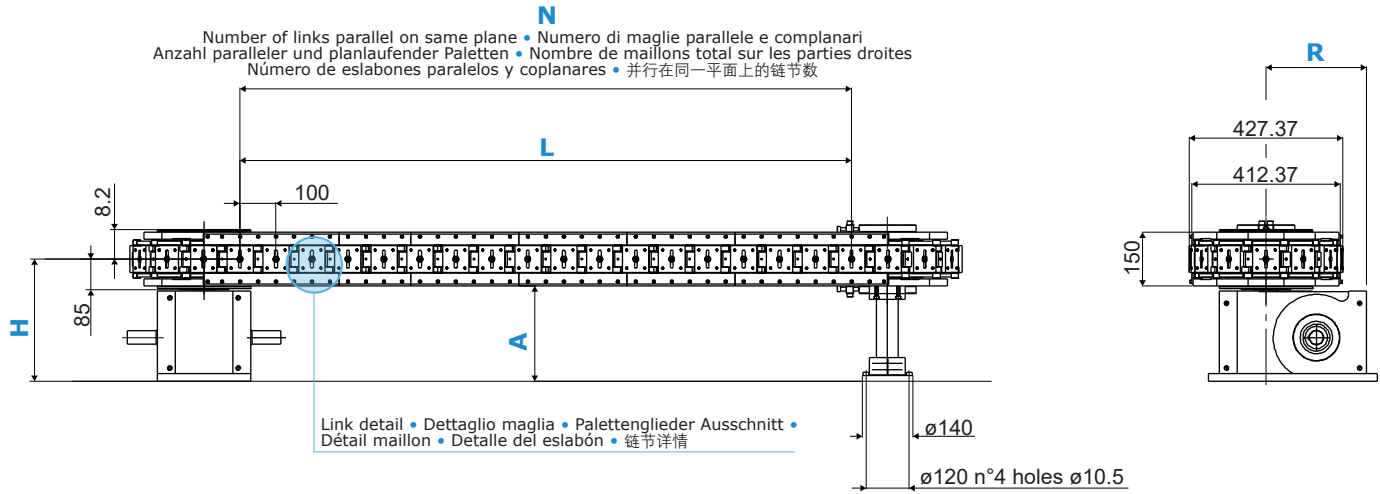
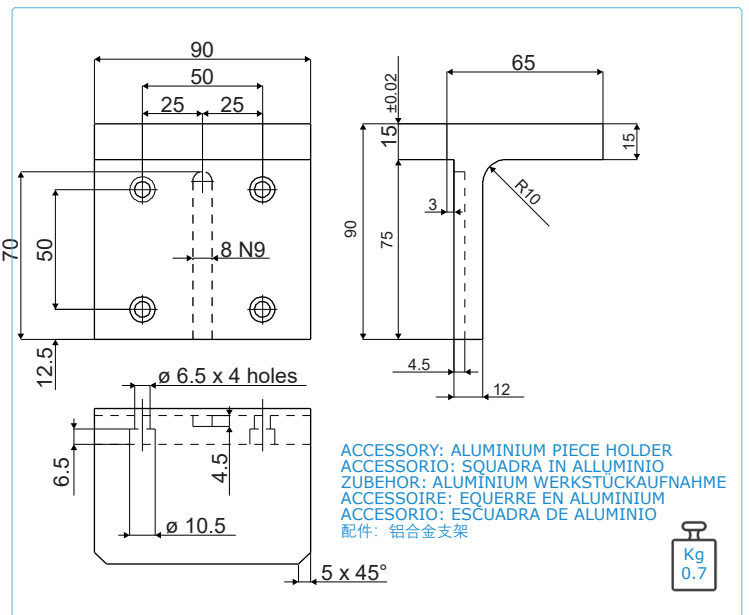
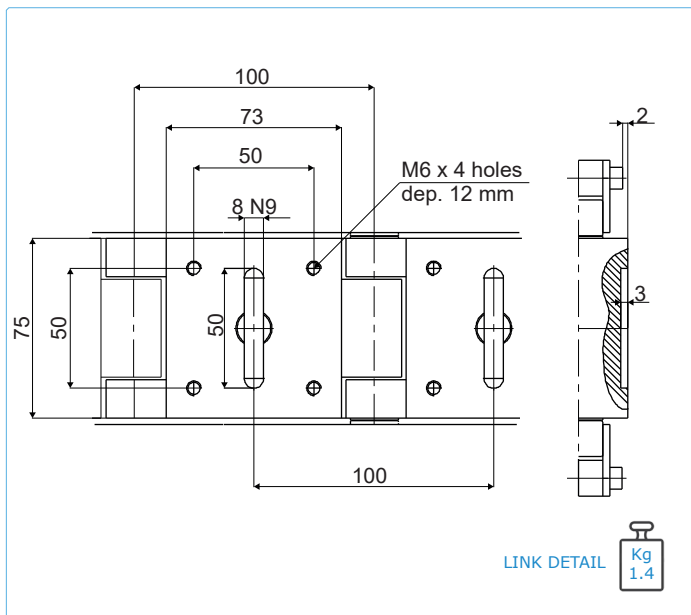



# TXL 100

k	INDEX DRIVE		
	IGA 125	IGA 140	IGA 160
D(k6)	32	38	42
E	83	83	113
R	255	280	305
G	220	260	290
H	304	339	358
A	229	264	283

INDEX DISTANCE	
Stops	Stroke [mm]
12	100
6	200

N° Pallet	MODULES COMPOSITION				I (mm)	L (mm)	N	Kg
	T	S	I	F				
28	1	-	-	1	799.566	600	7+7	320
32	1	1	-	1	999.566	800	9+9	365
34	1	-	1	1	1099.566	900	10+10	385
36	1	2	-	1	1199.566	1000	11+11	410
38	1	1	1	1	1299.566	1100	12+12	430
40	1	-	2	1	1399.566	1200	13+13	450
42	1	2	1	1	1499.566	1300	14+14	475
44	1	1	2	1	1599.566	1400	15+15	495
46	1	-	3	1	1699.566	1500	16+16	515
48	1	2	2	1	1799.566	1600	17+17	540
50	1	1	3	1	1899.566	1700	18+18	560
52	1	-	4	1	1999.566	1800	19+19	580
54	1	2	3	1	2099.566	1900	20+20	605
56	1	1	4	1	2199.566	2000	21+21	625
58	1	-	5	1	2299.566	2100	22+22	645
60	1	2	4	1	2399.566	2200	23+23	670
62	1	1	5	1	2499.566	2300	24+24	690
64	1	-	6	1	2599.566	2400	25+25	710
66	1	2	5	1	2699.566	2500	26+26	735
68	1	1	6	1	2799.566	2600	27+27	755
70	1	-	7	1	2899.566	2700	28+28	800
72	1	2	6	1	2999.566	2800	29+29	820
74	1	1	7	1	3099.566	2900	30+30	840
76	1	-	8	1	3199.566	3000	31+31	865
78	1	2	7	1	3299.566	3100	32+32	885
80	1	1	8	1	3399.566	3200	33+33	905
82	1	-	9	1	3499.566	3300	34+34	930
84	1	2	8	1	3599.566	3400	35+35	950
86	1	1	9	1	3699.566	3500	36+36	970
88	1	-	10	1	3799.566	3600	37+37	995
90	1	2	9	1	3899.566	3700	38+38	1015
92	1	1	10	1	3999.566	3800	39+39	1035
94	1	-	11	1	4099.566	3900	40+40	1060
96	1	2	10	1	4199.566	4000	41+41	1080
98	1	1	11	1	4299.566	4100	42+42	1100
100	1	-	12	1	4399.566	4200	43+43	1125

Please consult CDS to recommend appropriate index drive and for longer lengths • Consultare CDS per determinare la corretta unità index e per lunghezze superiori • CDS gibt gerne Auskunft über die Getriebetypen und für größere Längen • Pour déterminer l'indexeur correct et pour des longueurs supérieure s'adresser au CDS • Consultar a CDS para determinar la correcta unidad index y para longitudes más largas • 请咨询 CDS 以推荐适当的分度驱动器和更长的长度