

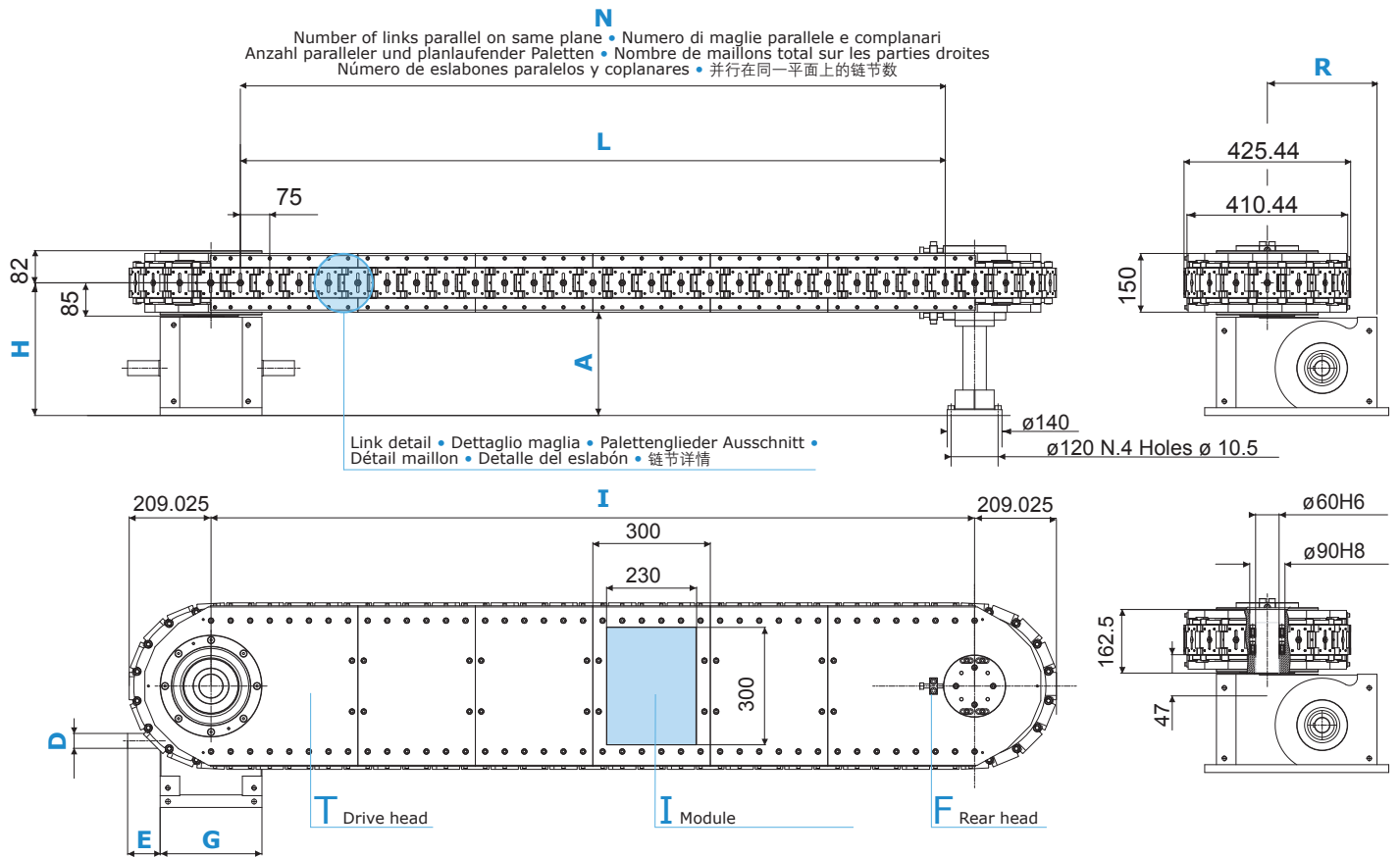

# TXL 75

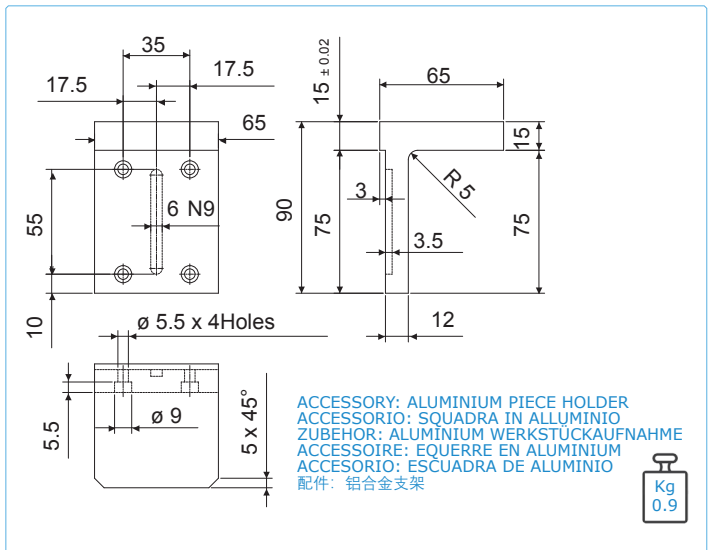

Area available on each element for tooling or through opening • Area disponibile in ogni modulo per lavorazioni o per apertura passante • Verfügbar sind Werkzeuge oder Öffnungen auf den einzelnen Flächen der Elementen  
 • Surface disponible sur chaque module pour montages appuis de fixation ou passage • Area disponible en cada módulo para elaboración o apertura pasante • 每个链节上都有工作和通过的区域

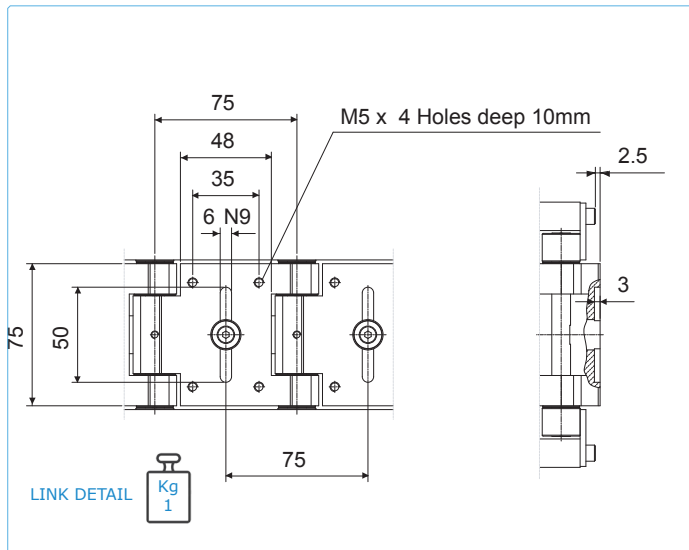



# TXL 75

k	INDEX DRIVE		
	IGA 125	IGA 140	IGA 160
D(k6)	32	38	42
E	83	83	113
R	255	255	305
G	220	260	290
H	304	339	358
A	229	264	283

INDEX DISTANCE	
Stops	Stroke [mm]
16	75
8	150

N° Pallet	MODULES COMPOSITION			I (mm)	L (mm)	N	Kg
	T	I	F				
36	1	-	1	749.818	600	9+9	320
44	1	1	1	1049.818	900	13+13	387
52	1	2	1	1349.818	1200	17+17	454
60	1	3	1	1649.818	1500	21+21	521
68	1	4	1	1949.818	1800	25+25	588
76	1	5	1	2249.818	2100	29+29	655
84	1	6	1	2549.818	2400	33+33	722
92	1	7	1	2849.818	2700	37+37	789
100	1	8	1	3149.818	3000	41+41	856

Please consult CDS to recommend appropriate index drive and for longer lengths • Consultare CDS per determinare la corretta unità index e per lunghezze superiori • CDS gibt gerne Auskunft über die Getriebetypen und für größere Längen • Pour déterminer l'indexeur correct et pour des longueurs supérieure s'adresser au CDS • Consultar a CDS para determinar la correcta unidad index y para longitudes más largas • 请咨询 CDS 以推荐适当的分度驱动器和更长的长度