

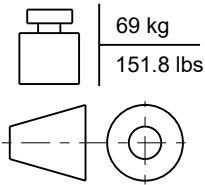

ITF-TRF

C024/1 - 04/2026

Rotating element • Elemento rotante • Drehelement • Élément tournant • Elemento de giro • 出旋轉元件

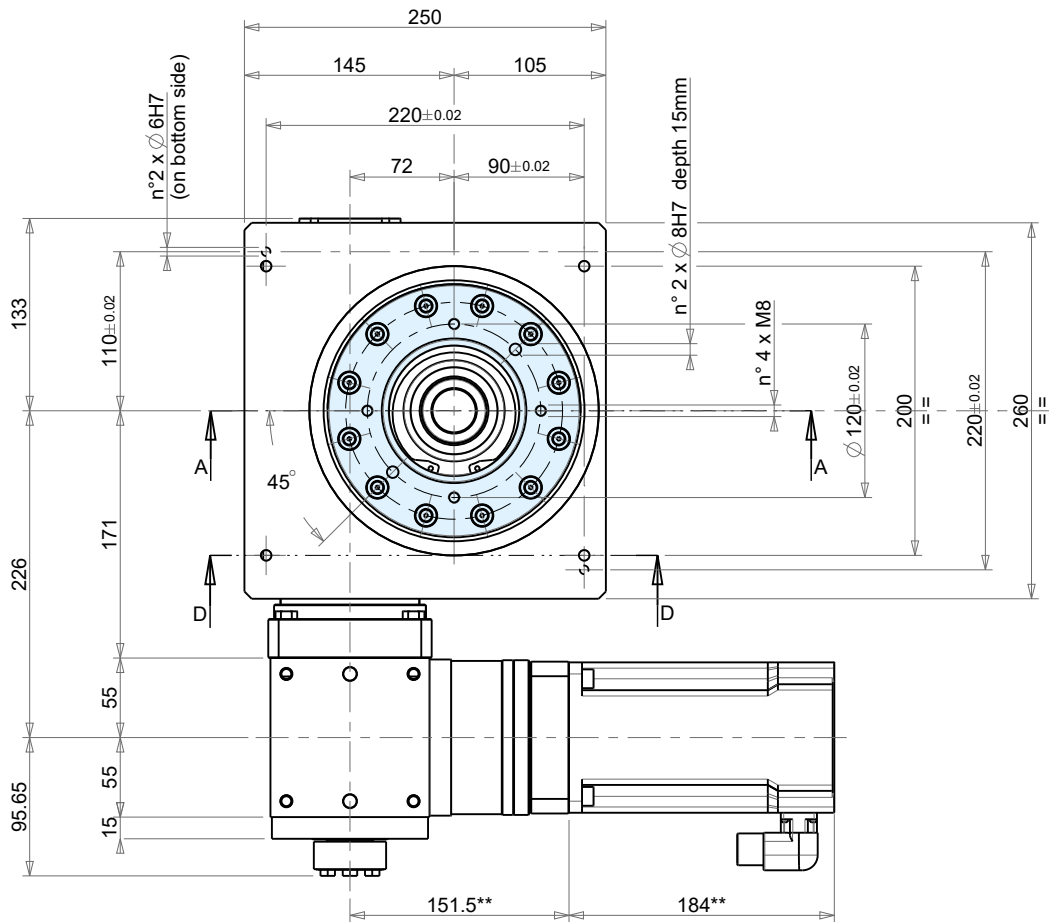
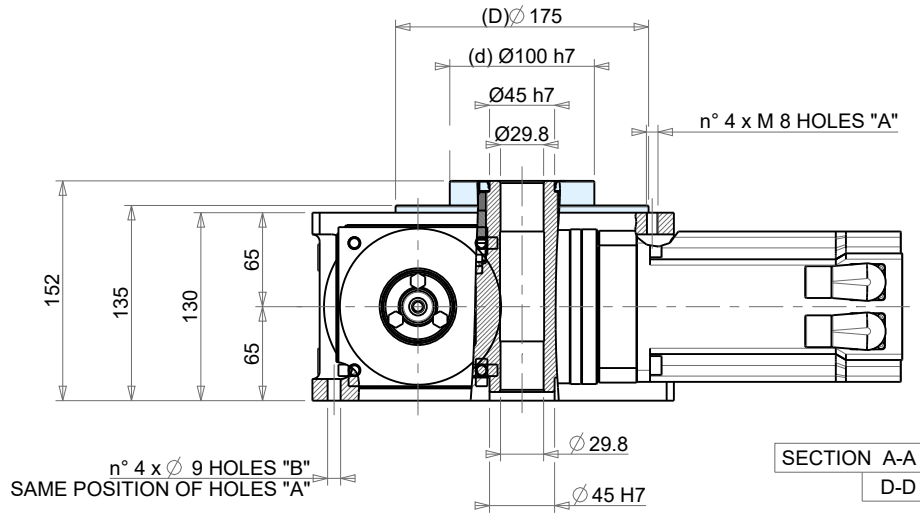

** = Dimension with servomotor Beckhoff - AM8551xx00

ITF 150	Reference Riferimento Bezug Référence Referencia 参考	Concentricity Concentricità Konzentrität Concentricité Concentricidad 同心度	Planarity Planarità Planheit Planéité Planaridad 平面度	Accuracy Precisione Teilgenauigkeit Précision Precisión 精度 Standard	Threaded holes position Posizione fori filettati Löcherposition Position des trou taraudé Posición orificios roscados 螺纹孔位置精度	Tolerance in compliance with Tolleranze secondo Toleranzen gemäß Tolérances selon Tolerancias con arreglo a 公差符合
	d	± 0.015 mm				UNI - ISO 2768-1 EN 22768-1
	D		± 0.015 mm			
	Rp			± 0.015°		



Unit		IT 150-12	
Total ratio		60 :1	
Max. rotary diameter		1 200 mm	
Max. output torque		178 N m	
Max. Application Inertia		18.75 kg m ²	
Internal inertia @ motor shaft		0.004450 kg m ²	
t _{360°}		1.73 s	
Max motor speed		5 000 min ⁻¹	
Max acceleration		9.50 rad/s ²	
Rated motor torque (max)		4.40 N m	
Gearbox code		ATB-FC110 1:5	APEX
Servo code		AM8551-xG00	Beckhoff

