

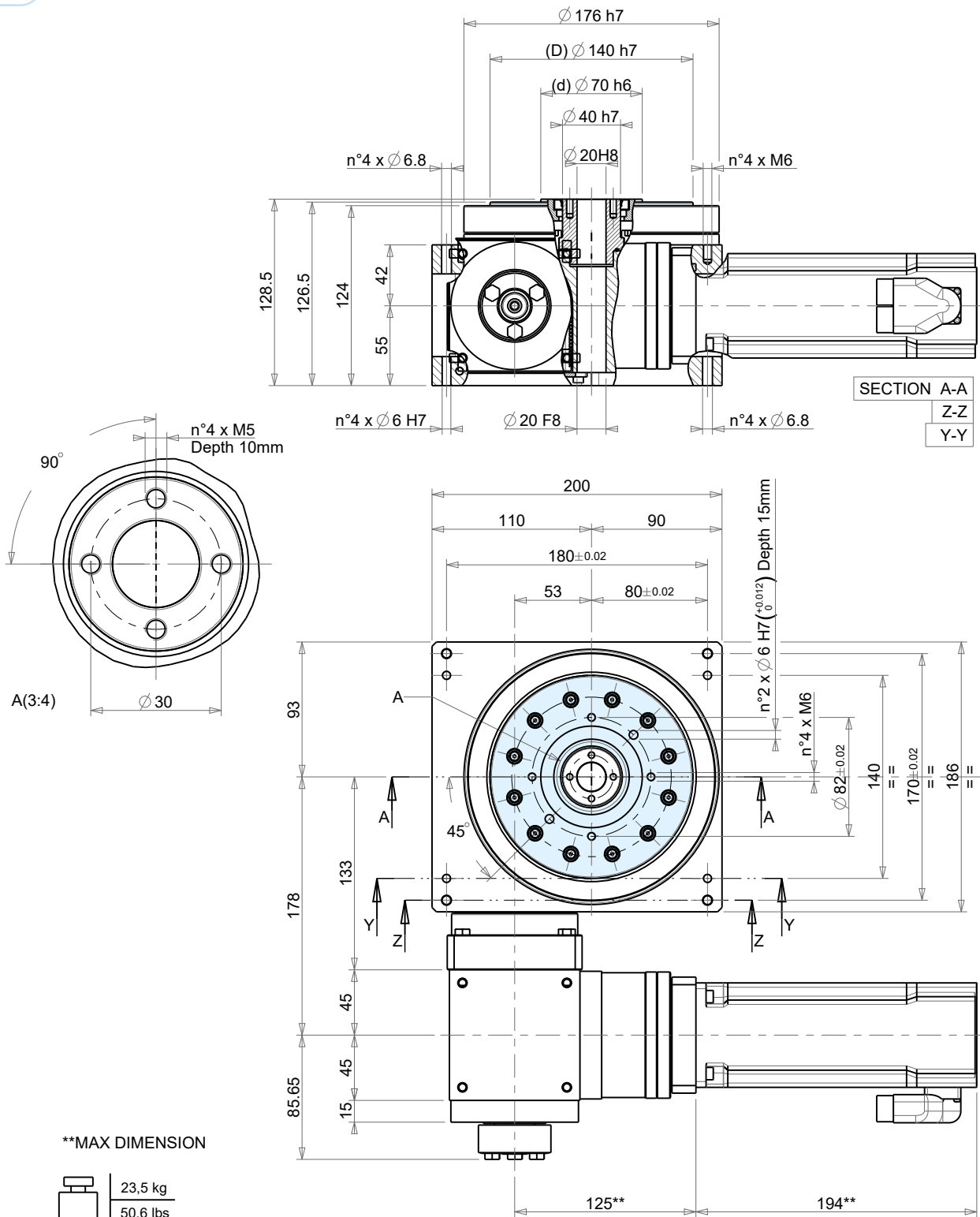

Rotating element • Elemento rotante • Drehelement • Élément tournant • Elemento de giro • 出旋轉元件



**MAX DIMENSION

23,5 kg
50.6 lbs

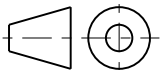

** = Dimension with servomotor Beckhoff - AM8532xx00

| TRF 110 | Reference Riferimento Bezug Référence Referencia 参考 | Concentricity Concentricità Konzentrizität Concentricité Concentricidad 同心度 | Planarity Planarità Planheit Planéité Planaridad 平面度 | Accuracy Precisione Teilgenauigkeit Précision Precisión 精度 Standard | Threaded holes position Posizione fori filettati Löcherposition Position des trou taraudé Posición orificios roscados 螺纹孔位置精度 | Tolerance in compliance with Tolleranze secondo Toleranzen gemäß Tolérances selon Tolerancias con arreglo a 公差符合 |
|------------|--|--|---|---|--|---|
| | | | | | | |
| | d | $\pm 0.01\ \text{mm}$ | | | | UNI - ISO 2768-1 EN 22768-1 |
| | D | | $\pm 0.01\ \text{mm}$ | | | |
| | Rp | | | $\pm 0.021^{\circ}$ | | |



| Unit | | TR 110-12 | |
|--------------------------------|----------------------------|-----------|--|
| Total ratio | 60 :1 | | |
| Max. rotary diameter | 800 mm | | |
| Max. output torque | 89 N m | | |
| Max. Application Inertia | 4.42 kg m ² | | |
| Internal inertia @ motor shaft | 0.002313 kg m ² | | |
| t _{360°} | 1.19 s | | |
| Max motor speed | 6 000 min ⁻¹ | | |
| Max acceleration | 20.14 rad/s ² | | |
| Rated motor torque (max) | 2.20 N m | | |
| Gearbox code | ATB-FC090 1:5 | APEX | |
| Servo code | AM8532-xE00 | Beckhoff | |

