

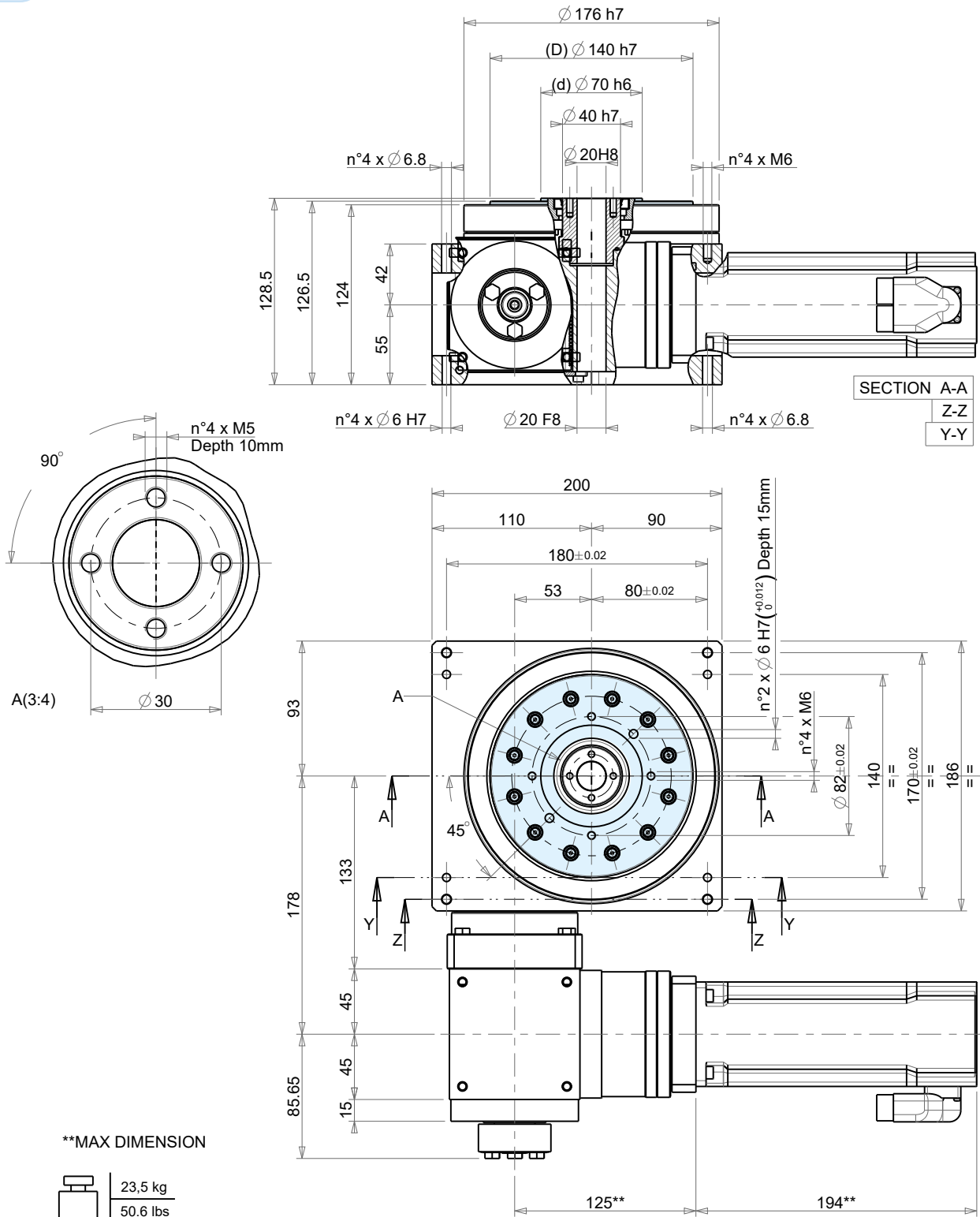

Rotating element • Elemento rotante • Drehelement • Élément tournant • Elemento de giro • 出旋轉元件



\*\*MAX DIMENSION

23.5 kg  
50.6 lbs

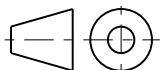

\*\* = Dimension with servomotor Beckhoff - AM8532xx00

TRF 160	Reference Riferimento Bezug Référence Referencia 参考	Concentricity Concentricità Konzentrität Concentricité Concentricidad 同心度	Planarity Planarità Planheit Planéité Planaridad 平面度	Accuracy Precisione Teilgenauigkeit Précision Precisión 精度	Threaded holes position Posizione fori filettati Löcherposition Position des trou taraudé Posición orificios roscados 螺紋孔位置精度	Tolerance in compliance with Tolleranze secondo Toleranzen gemäß Tolerancias selon Tolerancias con arreglo a 公差符合
				Standard		
	d	± 0.01 mm				UNI - ISO 2768-1 EN 22768-1
	D		± 0.01 mm			
	Rp			± 0.015°		



Unit		TR 160-12	
Total ratio		60 :1	
Max. rotary diameter		1 200 mm	
Max. output torque		222 N m	
Max. Application Inertia		18.89 kg m <sup>2</sup>	
Internal inertia @ motor shaft		0.005591 kg m <sup>2</sup>	
t <sub>360°</sub>		1.56 s	
Max motor speed		4 750 min <sup>-1</sup>	
Max acceleration		11.75 rad/s <sup>2</sup>	
Rated motor torque (max)		5.50 N m	
Gearbox code		ATB-FC110 1:5	APEX
Servo code		AM8551-xJ00	Beckhoff

